

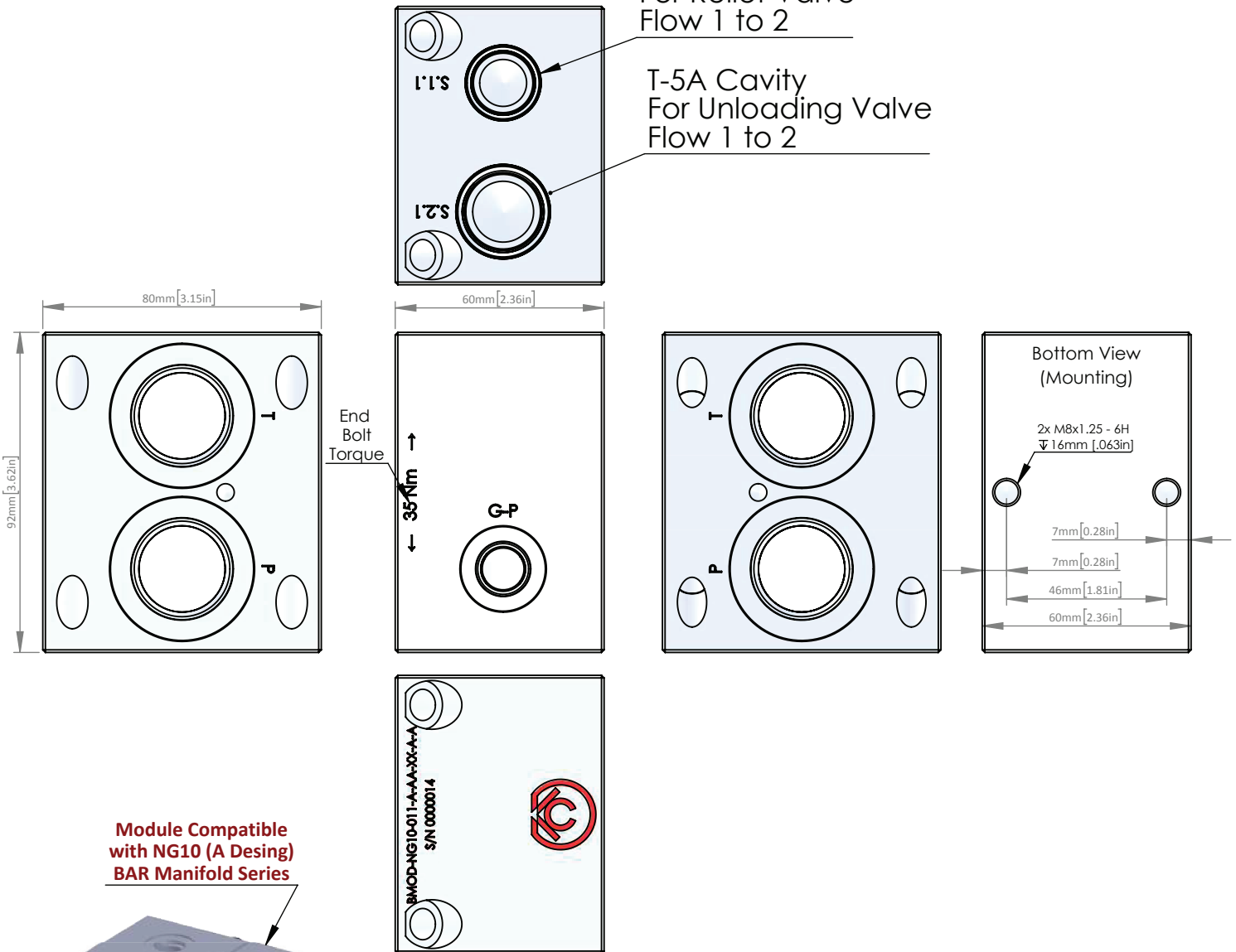

T-10A Cavity
For Relief Valve
Flow 1 to 2

T-5A Cavity
For Unloading Valve
Flow 1 to 2



Module Compatible
with NG10 (A Desing)
BAR Manifold Series

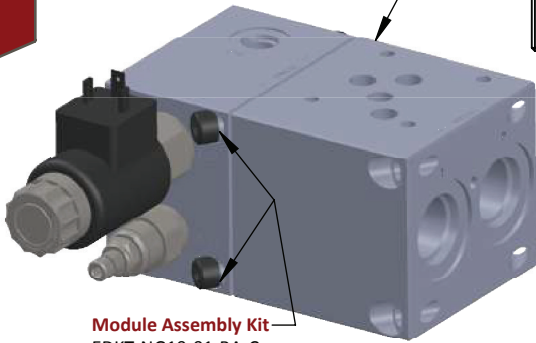

Module Assembly Kit
EDKT-NG10-01-BA-C
See Bolt Kit Section
for Details

Consult Factory
for All Other
Dimensional Data

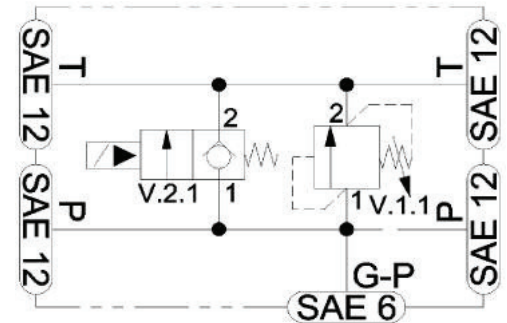

<p>BMOD-</p> <ul style="list-style-type: none"> Product Family- Bar Manifold MODULE 	<p>NG10-</p> <ul style="list-style-type: none"> Interface - NG10 (D05) 4401-05-04-0-05 	<p>011-</p> <ul style="list-style-type: none"> Option • 011 T-10A Relief T-5A Unloader 	<p>A-</p> <ul style="list-style-type: none"> Port Type- A: SAE To join SAE to SAE BAR manifolds 	<p>**-</p> <ul style="list-style-type: none"> Material • AA: Aluminum • 6061T6 • 210 BAR • DA: Ductile Iron • 654512 • 350 BAR 	<p>XX-</p> <ul style="list-style-type: none"> Surface Finish XX: Bare Metal Special Surface Finish Options Available Upon Special Request 	<p>A</p> <ul style="list-style-type: none"> Design Variant A: Design A
--	---	---	---	--	---	---

Subject to Change: CTLG-01-001A